

Draft Instructions

Please follow the following steps in order to get the correct draft

- Download the PDF and Print it out on A4 size Paper.
- Ensure that your Printer is set to General and Page Position is Centered.
- Cut along the outer margins printed on the sheets
- Join the sheets together following the number pattern on them, as shown in the reference image below
- Your Draft is Ready

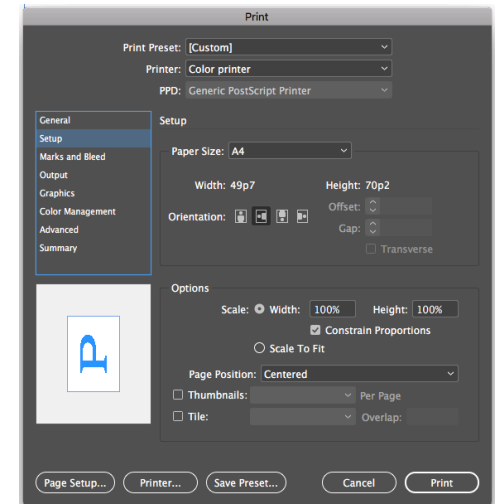
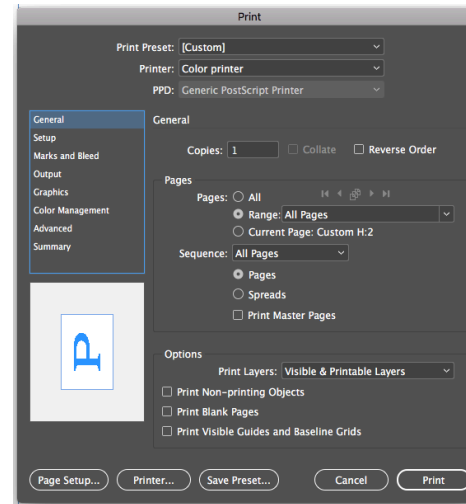

Size Chart

Size / Measurements	XS	S	M	L	XL
Poncho Length with allowance	39"	40"	42"	43"	43"
Chest Length	9"	9"	9"	9"	9"
Across Chest	9.25"	9.5"	9.75"	10.25"	10.5"
Waist Length	14.5"	14.5"	15"	15.5"	15.5"
Across Waist	7.75"	8"	8.75"	9.5"	10"
Hip Length	20"	20"	20.5"	21"	21"
Across Hip	9.5"	10"	10.5"	11"	11.5"
Half across shoulder	16"	17"	18"	20"	22"
Allowance	1/4"	1/4"	1/4"	1/4"	1/4"

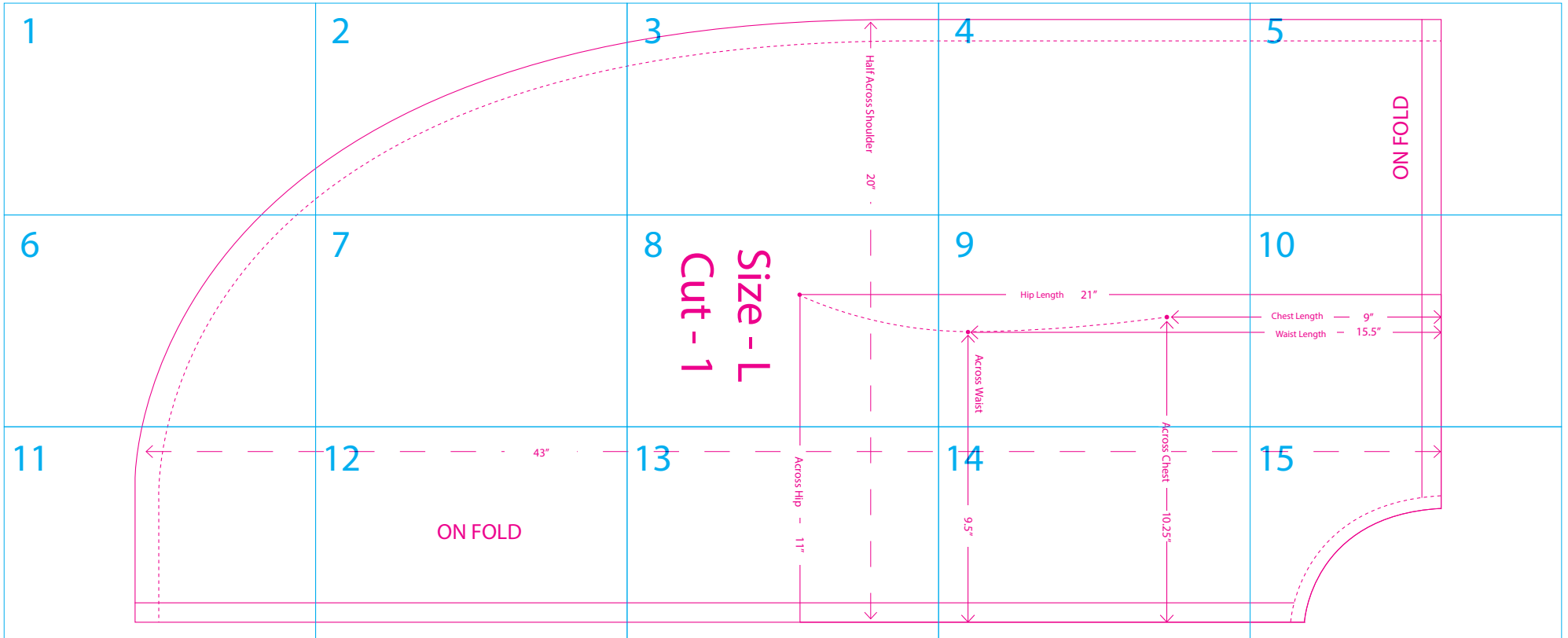



1

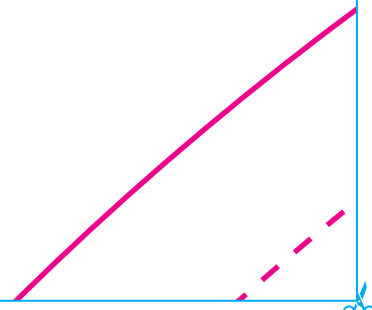

2

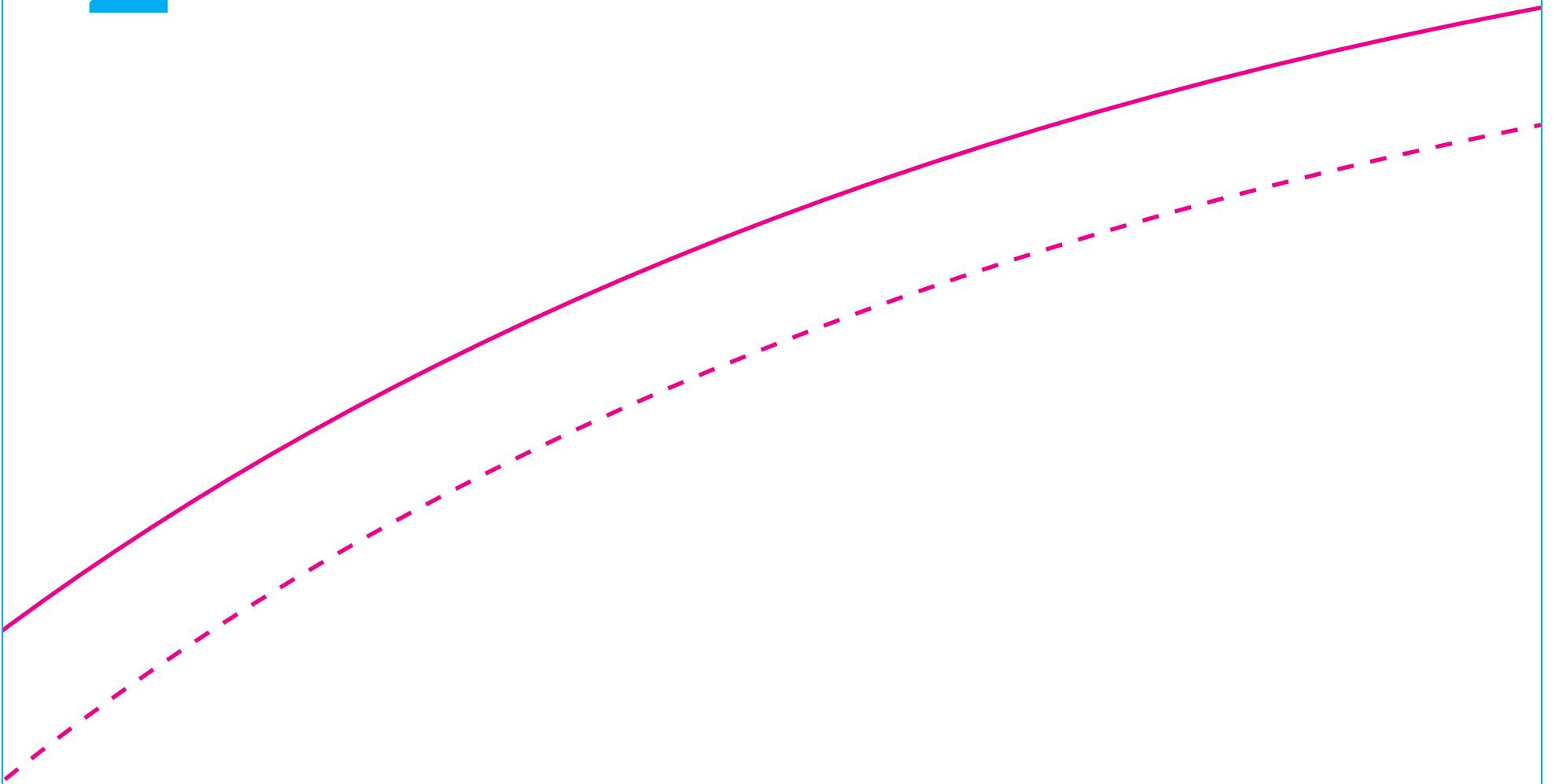

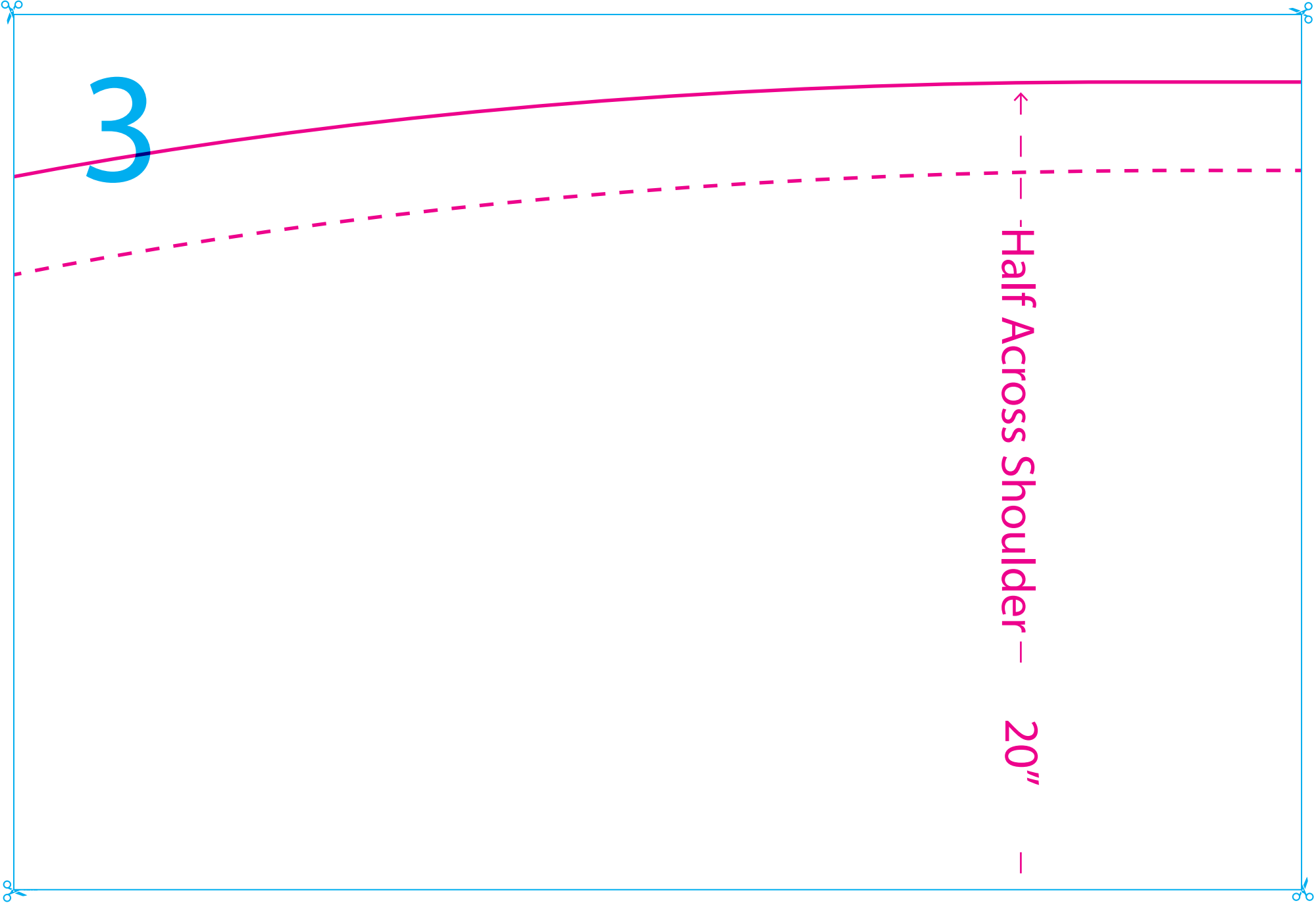



4



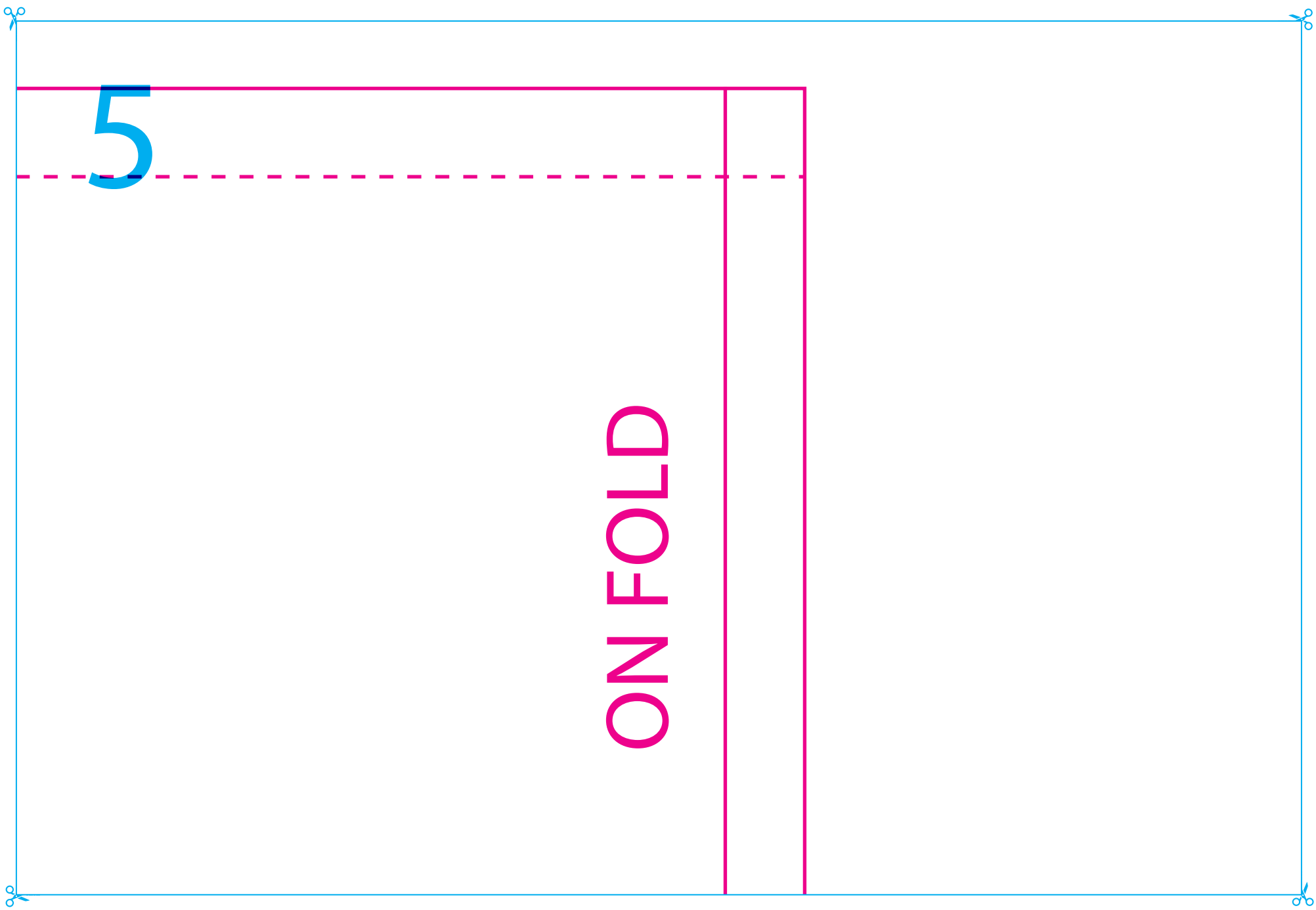

5

ON FOLD

6

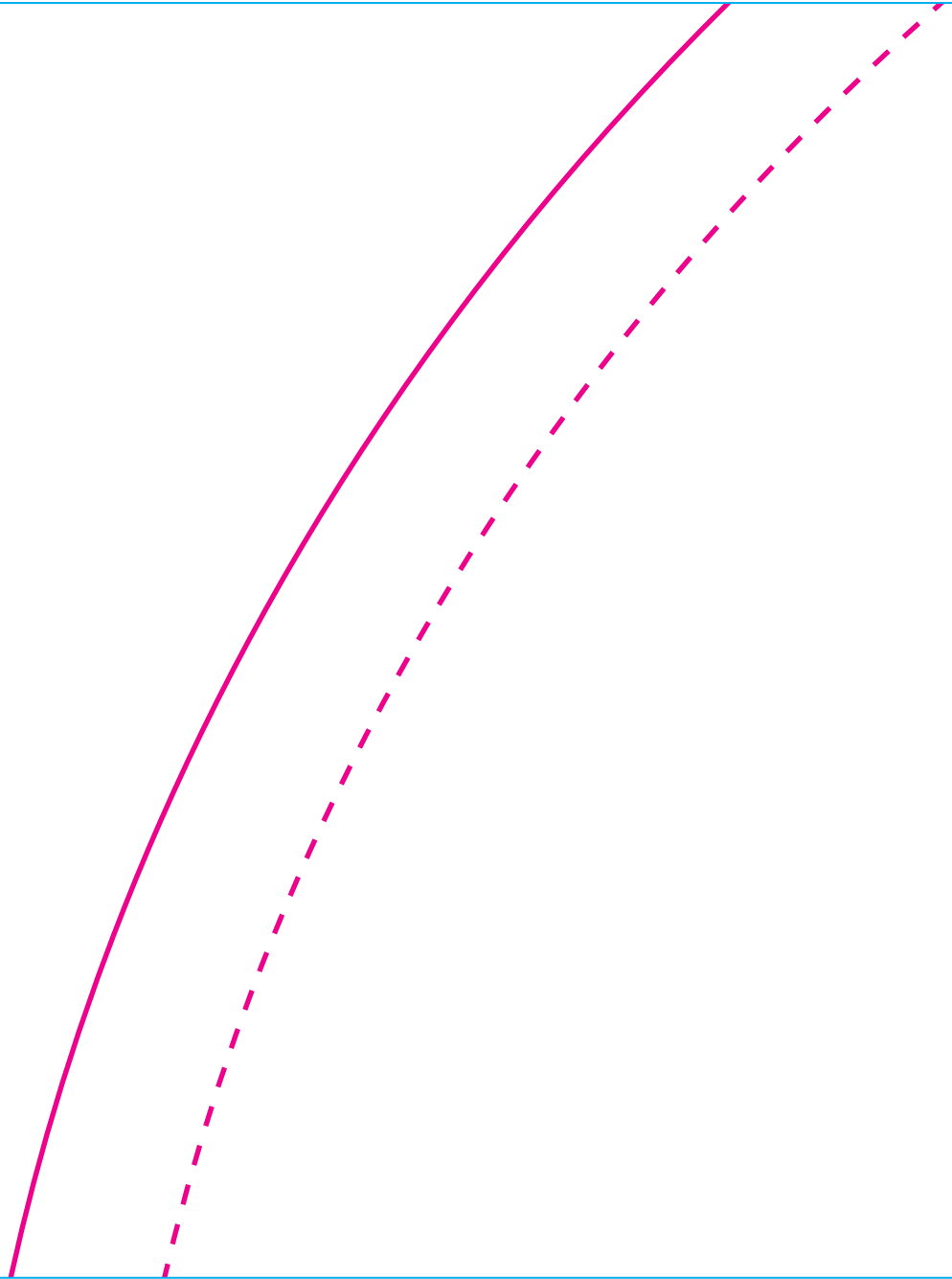

7

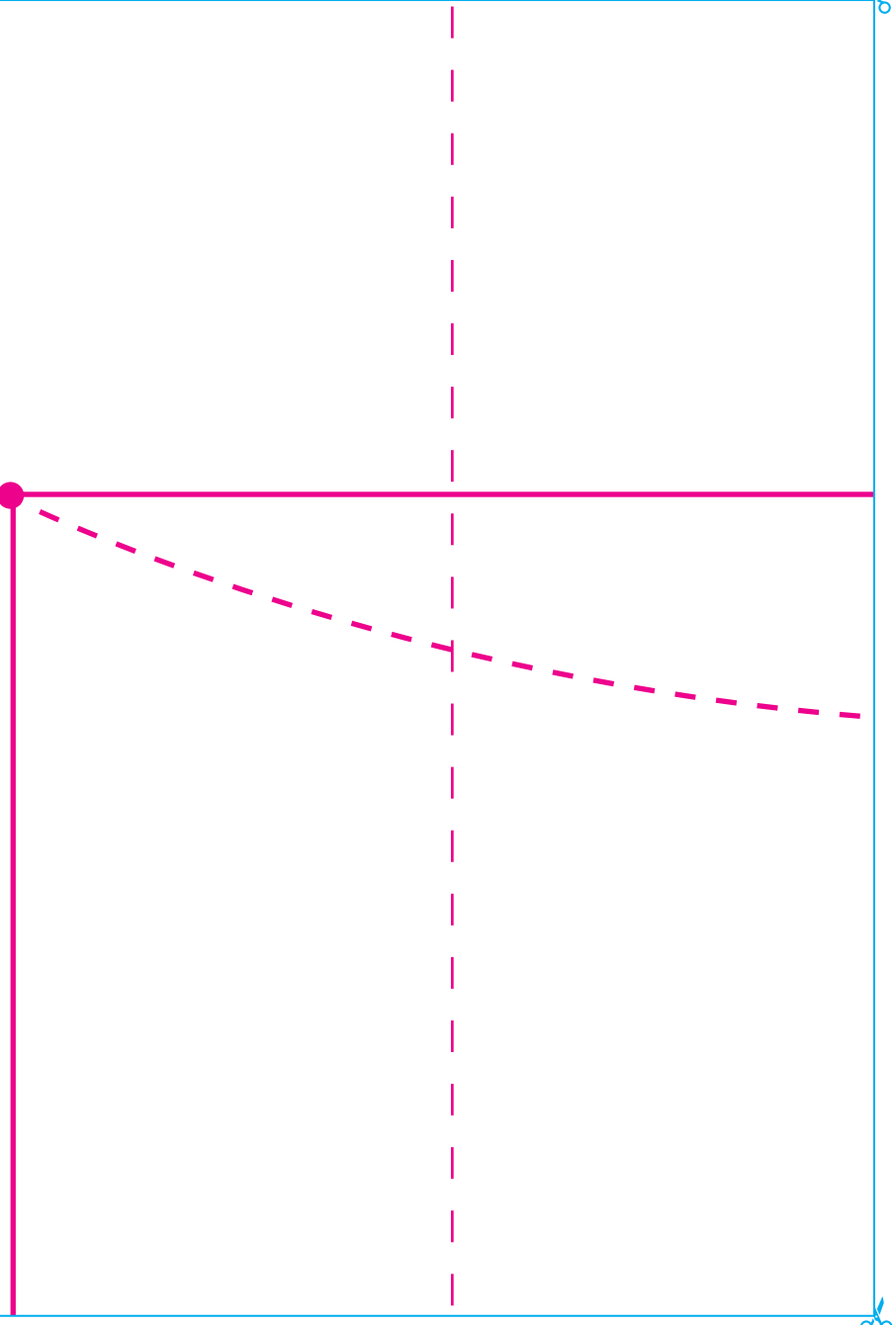

size - L
Cut - 1

8

9

Hip Length 21"

Across Waist

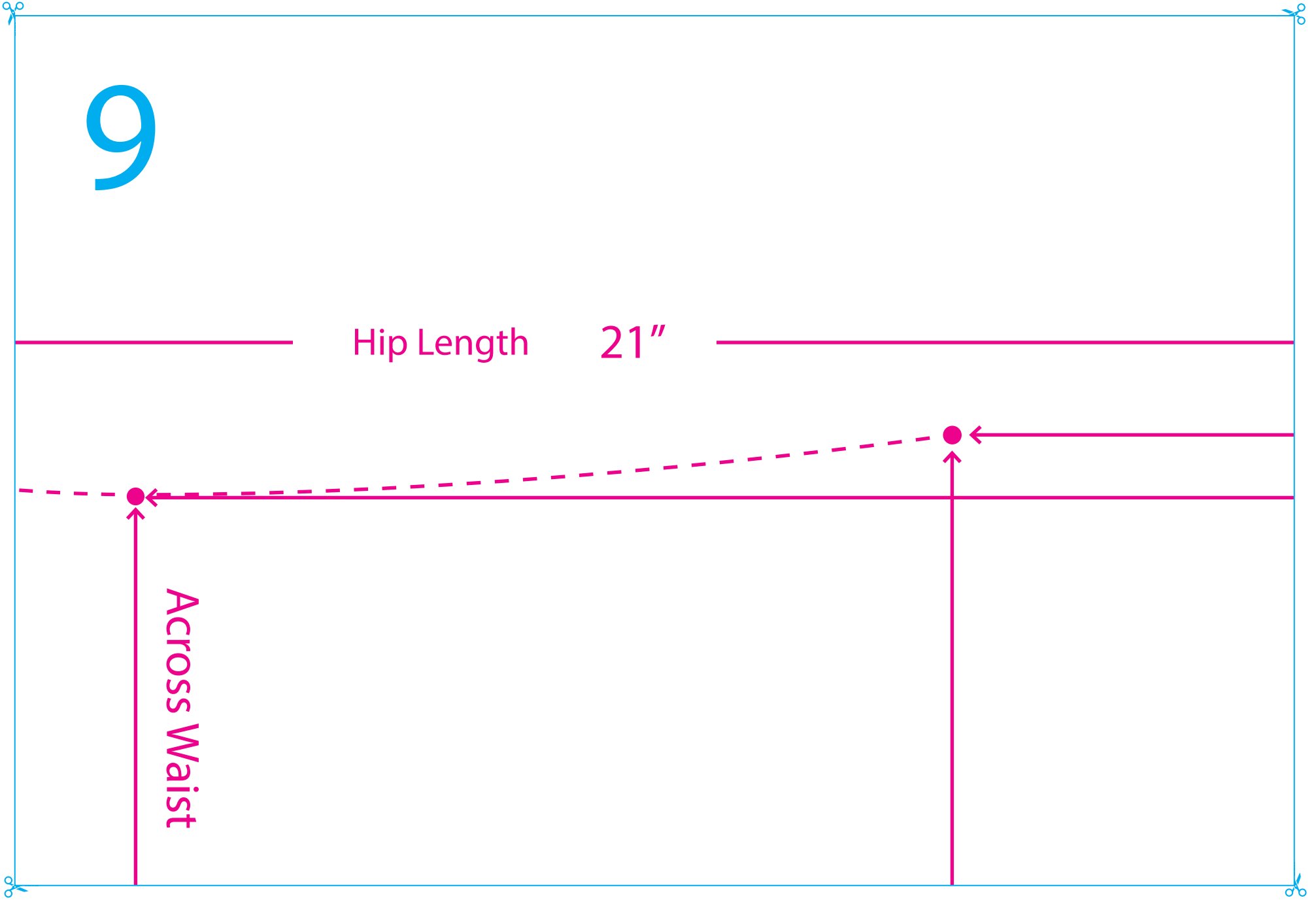

10

Chest Length — 9"

Waist Length — 15.5"





11

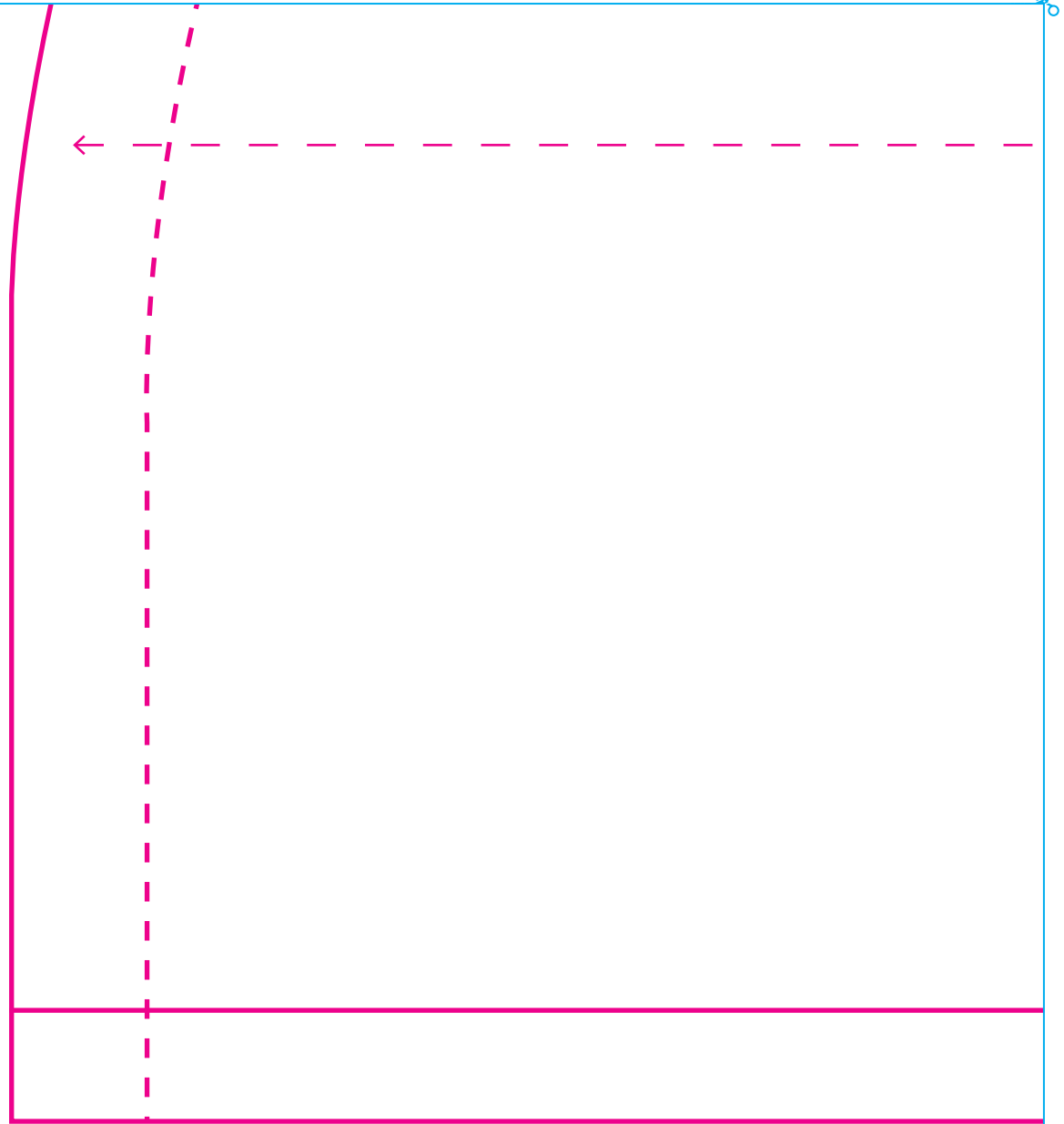



12

43"

ON FOLD



13

Across Hip - 11"



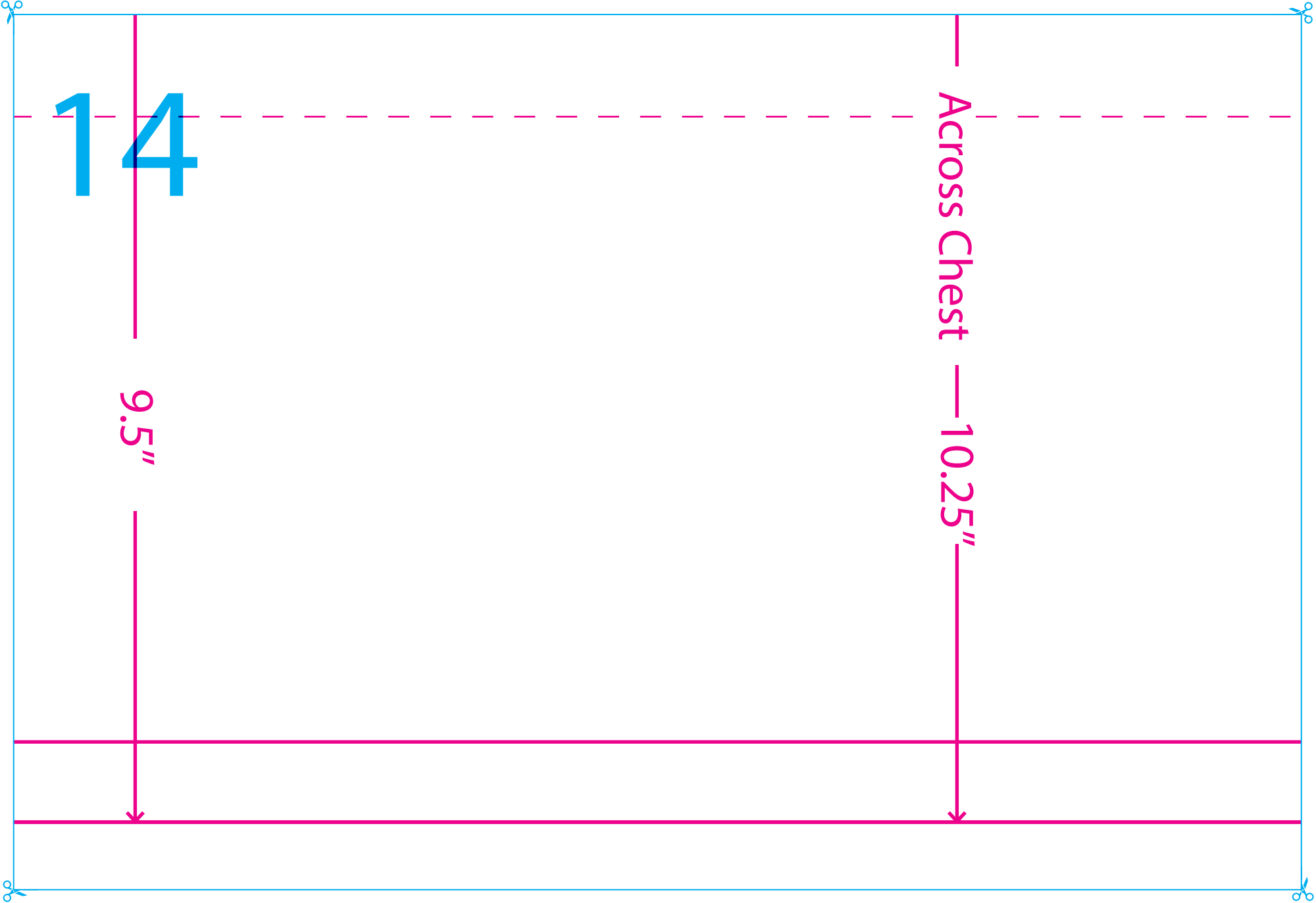

15

